

SMOKE & CO COMBO ALARM

Model **SC9120BA**

CAT. **SC9126BTCA**



**10YR CO SENSOR
10YR ALARM LIFE**

SMOKE & CO COMBO

Electrochemical CO sensor; Photoelectric smoke sensor.

LATCHING ALARM INDICATOR

Remembers which unit initiated an alarm.

SILENCE FEATURE

Silences nuisance alarms.

END OF LIFE SIGNAL

Provides audible notice when alarm needs to be replaced after 10 years.

BRK[®]

THE PROFESSIONAL STANDARD

**120V AC, 60Hz Wire-in
with 3V (two 1.5V AA) Battery Backup**

Description:

BRK Model SC9120BA (Cat. SC9126BTCA) is a wire-in, 120V AC 60Hz single and/or multiple station smoke and CO alarm specifically designed for residential and institutional applications including sleeping rooms of hospitals, hotels, motels, dormitories and other multi-family dwellings. Model SC9120BA complies with ULC S531, CSA 6.19-01, NFPA 72 and 720 and, ICC. They meet building codes where AC/DC with Silence smoke and CO alarms are required either separately or in combination. The alarms are interconnectable with up to 18 devices, of which 12 can be smoke alarms.

BRK SC9120BA alarm features a dual ionization smoke sensing chamber and an electrochemical carbon monoxide sensor, an 85dB horn and a "silence" feature. "Intelligent Sensing Technology" system is designed to reduce nuisance alarms. "Latching Alarm Indication" remembers which unit initiated an alarm. When interconnected in a series, the unit that triggered the alarm rapidly flashes its red LED indicator. After the alarm condition subsides, the initiating unit will store in memory or "latch" the information and begin to flash the LED indicator 2 seconds on, 2 seconds off. The "Perfect Mount" system features a gasketless base and a mounting bracket that keeps the alarm secure over a wide rotation range to allow for true alignment. Other Contractor Preferred features include a dust cover to keep alarm clean during construction, keyhole slots in the mounting bracket eliminate the need to remove the electrical box screws for installation. Two locking features are provided to prevent battery theft and/or theft of the unit. Connection to AC power is made with a "Quick-Connect" wiring harness. Installation is quick, easy and cost effective.



Model **SC9120BA**
 CAT. **SC9126BTCA**

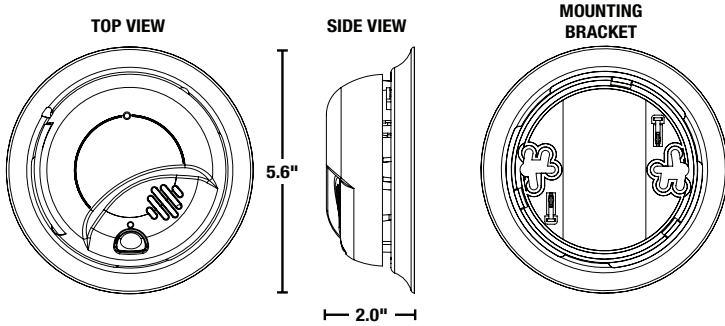

ARCHITECTURAL AND ENGINEERING SPECS

The combination smoke and CO alarm shall be a BRK Model SC9120BA (Cat. SC9126BTCA) and shall provide at a minimum the following features and functions:

1. An ionization smoke sensing chamber and an electrochemical CO sensor both with a 10 year service life.
2. Powered by 120V AC, 60Hz and have a monitored 9V battery backup and a solid state piezo horn rated at 85dB at 10 ft. and be capable of self restoring.
3. The unit shall perform self diagnostic tests and issue a malfunction warning (three chirps) if the unit malfunctions.
4. The unit shall have an "End of Life" signal. This signal should be capable of temporarily being silenced for up to 2 days. After about 2 days, the signal will resume. After about 2-3 weeks the signal cannot be silenced.
5. A visual power-on indicator to confirm unit is receiving AC power or has switched to battery backup mode. Separate LED's to indicate a smoke or CO alarm.
6. The CO sensor is adjusted not to detect CO levels below 30 PPM and will not alarm when exposed to constant levels of 30 PPM for 30 days. It will alarm at the following levels: 400 PPM CO between 4 and 15 minutes, 150 PPM CO between 10 and 50 minutes and 70 PPM CO between 60 and 240 minutes.
7. Two Latching features: Alarm Latch to easily identify initiating alarm after alarm condition has subsided. Low battery latch: to visually identify which unit is in low battery condition. Two Silence Features: Alarm Silence to temporarily silence nuisance alarms. Low Battery Silence to silence low battery chirp for up to 8 hours.
8. Two Locking features - tamper resistant locking pins that lock battery drawer and/or alarm to mounting bracket.
9. The unit shall be capable of operating between 40°F (4°C) and 100°F (38°C) and relative humidity between 10% and 95%.
10. The unit shall have a plug in connector and be capable of interconnection of up to 18 alarms, 12 of which can be smoke alarms.
11. The unit shall at a minimum meet the requirements of ULC S531, CSA 6.19-01, NFPA 72 and 720, and ICC.

INSTALLATION OF ALARM

Installation of this combination alarm must conform to all Canadian electrical codes. It is recommended that all units be on the same fuse or circuit breaker. If codes do not permit, be sure the neutral wire is common to both phases.

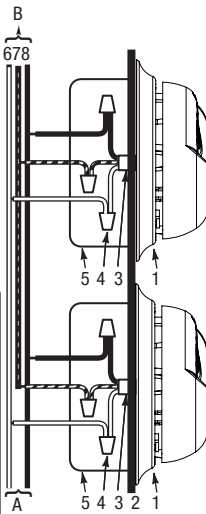

THE PARTS OF THIS ALARM

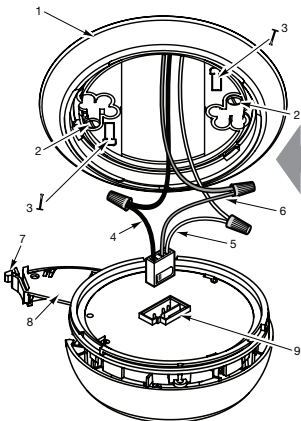

1. Mounting bracket
2. Mounting Slots
3. Locking Pins
4. Hot (Black) AC Wire
5. Neutral (White) AC Wire
6. Interconnect (Orange) Wire
7. Battery Drawer Latch
8. Battery Drawer - Install 9V battery here
9. Quick-Connect Plug

- A. Unswitched 120VAC 60 Hz source
 B. To additional units; Maximum = 18 total (Maximum 12 Smoke Alarms)

1. Smoke /CO Alarm
2. Ceiling or Wall
3. Power Connector
4. Wire Nut
5. Junction Box
6. Neutral Wire (White)
7. Interconnect Wire (Orange)
8. Hot Wire (Black)

TECHNICAL SPECS

Alarm Dimensions:	5.6 Dia. x 2.0" H
Weight:	8.5 oz
Operating Voltage:	120V AC 60Hz w/ 9V alkaline battery backup
Operating Current:	0.09 amps (standby/alarm)
Temperature Range:	40°F (4°C) to 100°F (38°C)
Humidity Range:	10% to 95% relative humidity (RH)
Audio Alarm:	85dB at 10 feet
Test/Silence:	Electronically simulates smoke or CO condition, causing the unit to alarm. Press and hold test/silence button.
Alarm Reset:	Automatic when smoke or CO clears
Interconnections:	Up to 18 units of First Alert or BRK Smoke, CO and Heat Alarms. Maximum of 12 smoke alarms. See user's manual for details.
Smoke Sensor:	Ionization
CO Sensor:	Electrochemical
Indicator Lights/Sounds:	AC Power: Constant Green LED DC Power: Intermittent Green LED Local Alarm: Red LED flashes rapidly Remote Alarm: Red LED out. Latching Alarm: Red LED flashes 2 sec. on/2 sec. off after local alarm Low Battery Latch: Green LED flashes on for 2 seconds, off for 2 seconds. End of Life: 5 green LED flashes, 5 chirps once per minute
Listing:	Certified to ULC STD S531 & CSA 6.19-01

SHIPPING SPECS

Individual Carton Dimensions	5.7" L x 2.3" W x 5.7" H
Weight:	0.7 lbs.
Cube:	.04 ft ³
UPC:	0 29054 01041 4
Master Carton Dimensions	6.2" L x 14.3" W x 12.4" H
Master Pack:	12
Weight:	8.5 lbs
Cube:	0.6 ft ³
I2of5:	200 29054 01041 8
Pallet Information	
Cases per Layer:	19
Number of Layers:	3
Cases per Pallet:	57
Units per Pallet:	684
Cube:	42.2 ft ³
Weight:	516 lbs.



© 2021 BRK Brands, Inc. All rights reserved. Distributed by BRK Brands, Inc., Aurora, Illinois 60504. BRK Brands, Inc. is a subsidiary of Newell Brands Inc. (NASDAQ: NWL).